

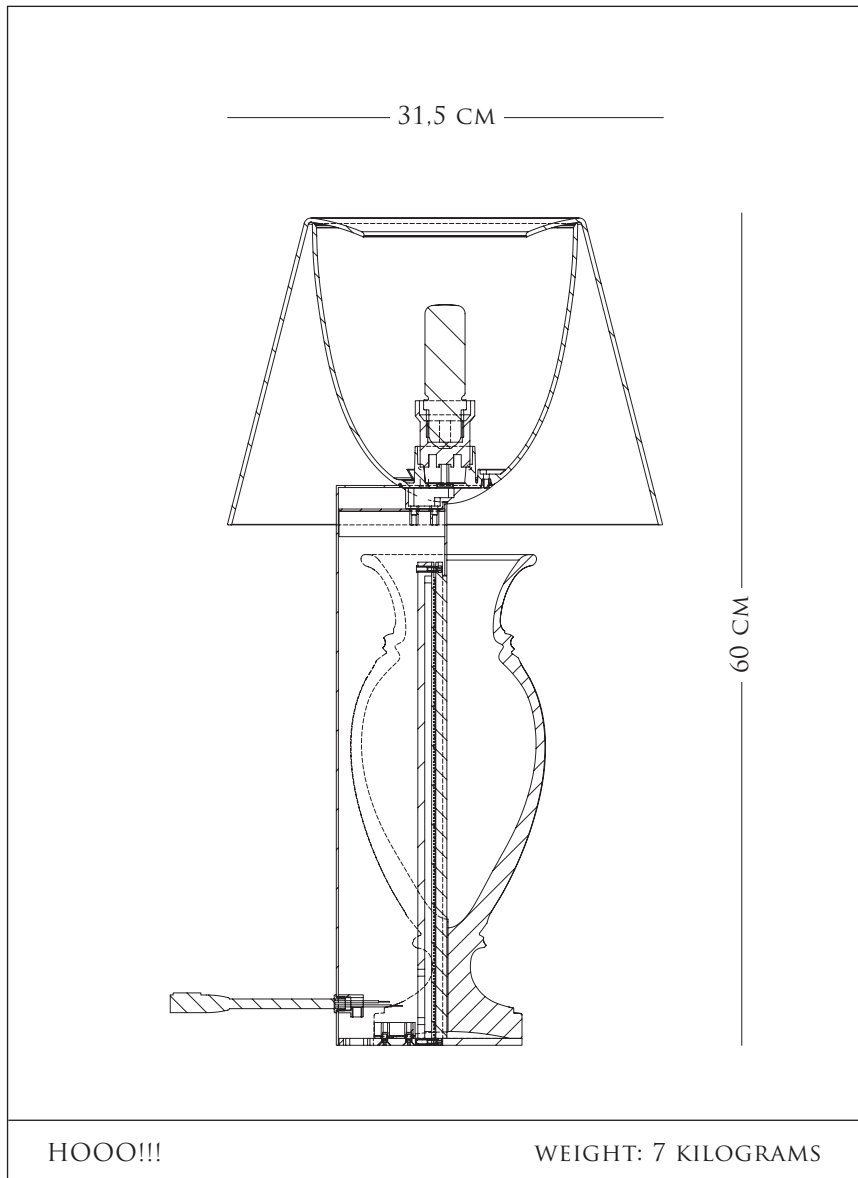

HOOO!!!

FLOS AND BACCARAT PRESENT
PHILIPPE STARCK'S NEW LAMP HOOO!!!
WITH TEXT BY JENNY HOLZER
AND HANDCRAFTED BY BACCARAT

LIMITED EDITIONS OF 49



HOOO!!!

LIMITED EDITION: 49

TABLE LUMINAIRE. OUTER BODY IN BLOWN, CAST CRYSTAL GLASS. INNER BODY POLISHED ALUMINUM.

FLUSH MOUNT LED DISPLAY WITH CUSTOM MADE CARDS AND HIGH PERFORMANCE MICRO LEDS WITH ONE PROCESSOR. ON/OFF SWITCH AT THE BOTTOM OF THE LAMP BODY. METHACRYLATE LED SCREEN. HIGH VACUUM METALLIZED AND UVA-PROTECTED.

INNER DIFFUSER IN INJECTION-MOLDED POLYMER.

LAMP SHADE IN HIGH VACUUM METALLIZED BLOWN GLASS AND UVA-PROTECTED.

HAND-POLISHED ALUMINUM BASE. NON-SLIP LAYER BETWEEN LUMINAIRE BASE AND BODY.

ALL COUPLING DETAILS IN HAND-POLISHED AND ZAPON-VARNISHED ALUMINUM.

100W E27 DIMMABLE HALOGEN LIGHT SOURCE.



INNER BODY POLISHED ALUMINUM

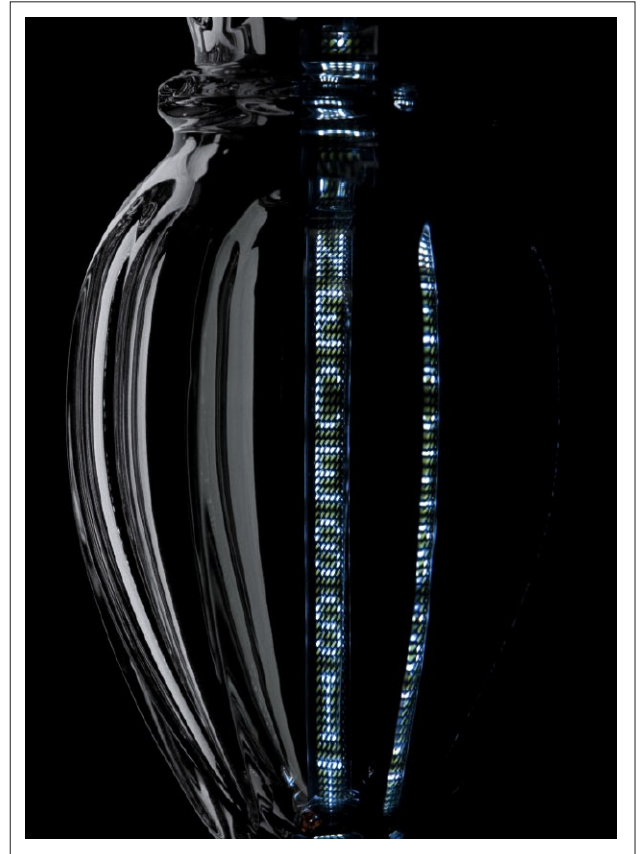

MICRO LEDS WITH ONE PROCESSOR

HOOO!!! DETAILS

HOOO!!! AND HAAA!!!

THIS IS A LAMP WITH A SPECIAL SHAPE; IT MERGES DIFFERENT WORLDS AND OPPOSING REALITIES. ITS DESIGN COMBINES TRADITION AND RESEARCH, CRAFTSMANSHIP AND INDUSTRY, ART AND DESIGN.

THE REFLECTIONS OF THE HAND-CUT, GROUND CRYSTAL BASE INTERACT WITH PROGRAMMED ELECTRONIC OR LED LIGHTS. THE TIMELESSNESS AND UNIQUENESS OF BACCARAT WORKMANSHIP IS JOINED BY TEXT FROM JENNY HOLZER'S "TRUISMS" AND "SURVIVAL" SERIES. HOLZER'S TEXTS ARE SHORT, DECLARATIVE STATEMENTS THAT SUMMARIZE, QUESTION, AND DEBATE HOW SOCIETIES ARE STRUCTURED AND VIEWED.

DESIGNED BY PHILIPPE STARCK FOR FLOS, THE LAMP IS AVAILABLE IN TWO VERSIONS: "HOOO!!!", THE TABLE MODEL, AND "HAAA!!!", THE FLOOR MODEL. WITH ITS TRANSPARENT AND REFLECTING OUTLINES, THE LAMP SEDUCES AND PLAYS WITH THE GAZE OF THE VIEWER. HOLZER'S PHRASES FLOW UNINTERRUPTED VERTICALLY ALONG THE CENTRAL PASSAGE OF THE LAMP. A NARROW, ELONGATED RECTANGULAR ELEMENT IN MIRROR-FINISH STEEL CUTS THE FACETED SHAPE OF THE CRYSTAL BASE PERPENDICULARLY AND DIFFUSES THE LIGHT.

STARCK'S FASCINATION WITH THE CREATIONS OF BACCARAT AND THE POTENTIAL OF CRYSTAL HELPED INAUGURATE THIS SPECIAL PROJECT. THIS COMBINATION OF POSSIBILITY AND TRADITION IS IN KEEPING WITH THE SOCIAL AND CULTURAL COMMITMENT THAT HAS ALWAYS IDENTIFIED FLOS, ITS WORKING METHODS, AND ITS PROJECTS. AS PIERO GANDINI EXPLAINS: "WE HAVE CHOSEN THE BEAUTIFUL BACCARAT VASES BECAUSE WE RESPECT THE PASSION AND DEDICATION WHICH BACCARAT AND HIS CRAFTSMEN CONTINUE TO USE IN THE EXPLORATION OF CRYSTAL, NOT BECAUSE FLOS WANTS TO BE INVOLVED IN LUXURY ITEMS. THE IDEA OF INSERTING LEDs IN MOVEMENT INSIDE THE STEEL BODY OF THE LAMP REMINDED US IMMEDIATELY OF JENNY HOLZER'S FANTASTIC INSTALLATIONS. WE LOVE HER TALENT AND MORAL COURAGE. JENNY HAS SELECTED SOME OF HER "TRUISMS" AND "SURVIVAL" SENTENCES WHICH NOW FLOW WITHIN THE CRYSTAL WITH SURPRISING RESULTS."

TO LOOK AT OR TO READ BY, THE LAMP BECOMES A CONVERSATION PIECE, A FRIENDLY BUT EVOCATIVE PRESENCE. A SOURCE OF MEDITATION AND A MEANS OF COMMUNICATION, THE PIECE MERGES SHAPE AND CONTENT, IMAGES AND WORDS.

PRODUCED IN NINE PIECES FOR THE FLOOR VERSION AND IN FORTY-NINE PIECES FOR THE TABLE VERSION, THE LAMP'S CAREFUL DESIGN AND THE EXTREME MANUAL WORKMANSHIP OF THE BACCARAT CRYSTAL AND MICRO LED BOARDS ACCOUNT FOR ITS PRICE. AS THE PRODUCTION CAPACITY IS VERY LIMITED, QUANTITY HAS BEEN DECIDED IN ADVANCE IN ORDER TO PREVENT CLIENTS FROM HAVING TO WAIT MANY YEARS.

JENNY HOLZER CREATED HER "TRUISMS" AND "SURVIVAL" SERIES IN THE LATE 1970S AND EARLY 1980S. THESE TEXT SERIES AND OTHERS BY THE AMERICAN ARTIST INTRODUCED HER WORK TO THE INTERNATIONAL CONTEMPORARY ART FIELD AND HAVE BECOME WELL-KNOWN EVER SINCE. FLASHING ON ELECTRONIC BOARDS AND CONCEALED AMONG NEWS AND ADVERTISING MEDIA IN LARGE METROPOLITAN CENTRES, THE SENTENCES AND MESSAGES HAVE POLITICAL AND IDEOLOGICAL CONNOTATIONS THAT QUESTION THE STATUS QUO OF SOCIETY, POLITICS, CULTURE.

PHILIPPE STARCK

“I LIKE TO OPEN THE DOORS TO PEOPLE’S BRAINS” – PHILIPPE STARCK

TO DISCOVER AN OBJECT OR A PLACE DESIGNED BY PHILIPPE STARCK IS TO WALK INTO A WORLD OF VIVID IMAGINATION AND TO LIVE FANTASY.

FOR MORE THAN 30 YEARS, THIS UNCONVENTIONAL CREATOR, DESIGNER AND ARCHITECT HAS BEEN BOLDLY PRESENT IN OUR EVERYDAY, CREATING OBJECTS THAT ARE “GOOD” BEFORE THEY ARE BEAUTIFUL, AND ICONIC DESTINATIONS THAT ARE PURE POETRY AND CHANGE THE VISION OF LIFE.

PHILIPPE STARCK’S EARLY INSPIRATION CAME FROM HIS FATHER WHO WAS AN AIRCRAFT ENGINEER AND MANUFACTURER.

SEVERAL YEARS AND SEVERAL PROTOTYPES LATER, AND PHILIPPE STARCK WAS COMMISSIONED TO WORK FOR FRENCH PRESIDENT FRANÇOIS MITTERRAND. ALSO AT THIS TIME HE STARTED CREATING FURNITURE FOR LEADING ITALIAN AND INTERNATIONAL EDITORS.

WHEN PHILIPPE STARCK DESIGNS A HOTEL OR RESTAURANT, HE WORKS MORE LIKE A MOVIE DIRECTOR, CREATING SCENARIOS TO BRING AND UPGRADE PEOPLE IN A MENTAL, IMAGINATIVE AND CREATIVE STORY. HIS HOTELS, THOUGH ALWAYS CARRYING THE CUTTING EDGE CREATIVITY, ALL BECAME TIMELESS ICONS AND HAVE BROUGHT A NEW DIMENSION TO THE INTERNATIONAL LANDSCAPE.

THROUGH HIS CONCEPT OF DEMOCRATIC DESIGN, WHICH IS TO “GIVE THE BEST TO AS MANY PEOPLE AS POSSIBLE,” STARCK APPEARED LIKE A PIONEER WHEN DESIGN WAS TURNED EXCLUSIVELY TOWARDS AN ELITE.

THERE IS LITTLE THAT HE HAS NOT SET HIS HAND TO: FROM FURNITURE AND FAMILY PRODUCTS TO HOUSES TO BE SOLD BY MAIL ORDER, FROM MOTORBIKES TO MEGA YACHTS, AND EVEN ART DIRECTION FOR SPACE PROJECTS ... AMONG OTHERS.

STARCK’S GREEN CREDENTIALS WERE EVIDENT WAY BEFORE IT BECAME POPULAR TO THINK ABOUT THE FUTURE OF THE PLANET. VERY EARLY ON, HE SET UP A COMPANY PRODUCING ORGANIC FOOD, AND RECENTLY LAUNCHED THE REVOLUTIONARY CONCEPT OF DEMOCRATIC ECOLOGY BY CREATING AFFORDABLE MICRO PERSONAL WINDMILLS, THAT SHALL BE FOLLOWED BY SOLAR BOATS AND HYDROGEN VEHICLES...

THIS INDEFATIGABLE AND REBELLIOUS CITIZEN OF THE WORLD CONSIDERS IT HIS DUTY TO SHARE HIS ETHIC AND SUBVERSIVE VISION OF A FAIRER WORLD AND CONTINUES TO BE TUNED IN TO OUR DREAMS, DESIRES AND NEEDS BY MAKING HIS WORK A POLITICAL AND CIVIC ACT BUT ALWAYS WITH LOVE AND HUMOUR.

JENNY HOLZER

FOR THIRTY YEARS, JENNY HOLZER HAS PRESENTED HER ASTRINGENT IDEAS, ARGUMENTS, AND SORROWS IN PUBLIC PLACES AND INTERNATIONAL EXHIBITIONS, INCLUDING 7 WORLD TRADE CENTER, THE REICHSTAG, THE VENICE BIENNALE, AND THE GUGGENHEIM MUSEUMS IN NEW YORK AND BILBAO.

HER MEDIUM, WHETHER FORMULATED AS A T-SHIRT, AS A PLAQUE, OR AS AN LED SIGN, IS WRITING, AND THE PUBLIC DIMENSION IS INTEGRAL TO THE DELIVERY OF HER WORK. STARTING IN THE 1970S WITH THE NEW YORK CITY POSTERS, AND UP TO HER RECENT LIGHT PROJECTIONS ON LANDSCAPE AND ARCHITECTURE, HER PRACTICE HAS RIVALED IGNORANCE AND VIOLENCE WITH HUMOR, KINDNESS, AND MORAL COURAGE.

HOLZER RECEIVED THE LEONE D'ORO AT THE VENICE BIENNALE IN 1990 AND THE PUBLIC ART NETWORK AWARD IN 2004. SHE HOLDS HONORARY DEGREES FROM OHIO UNIVERSITY, WILLIAMS COLLEGE, THE RHODE ISLAND SCHOOL OF DESIGN, AND THE NEW SCHOOL. HOLZER LIVES AND WORKS IN HOOSICK, NEW YORK.